

REINHOLD ENVIRONMENTAL Ltd.



## **2014 NO<sub>x</sub>-Combustion Round Table & Expo Presentations**

February 10 & 11, 2014, in Charlotte, NC / Hosted by Duke Energy

All presentations posted on this website are copyrighted by Reinhold Environmental, Ltd (RE). Any unauthorized downloading, attempts to modify or to incorporate into other presentations, link to other websites, or obtain copies for any other uses than the training of attendees to RE's Conferences is expressly prohibited, unless approved in writing by RE or the original presenter. RE does not assume any liability for the accuracy or contents of any materials contained in this library which were presented and/or created by persons who were not employees of RE.



Reinhold Environmental  
2014 NOx-Combustion Round Table  
February 10, 2014

**SOUTHERN RESEARCH  
INSTITUTE**

## Bench-Scale SCR Catalyst Testing

Ken Jeffers

# Topics Covered

- Purpose of Testing
- Testing Systems
- Sampling
- Measurements Conducted
- Testing Procedures
- Interpreting Results
- Pitfalls, difficulties, complications, etc

# Purposes of Testing

- Manufacturing QA/QC
- Product R&D
- Determine catalyst performance under varying conditions
- Verify performance guarantees
- Compare performance of fresh vs aged catalyst
- Determine deactivation trends
- Troubleshooting SCR performance problems

# Applications - Coal

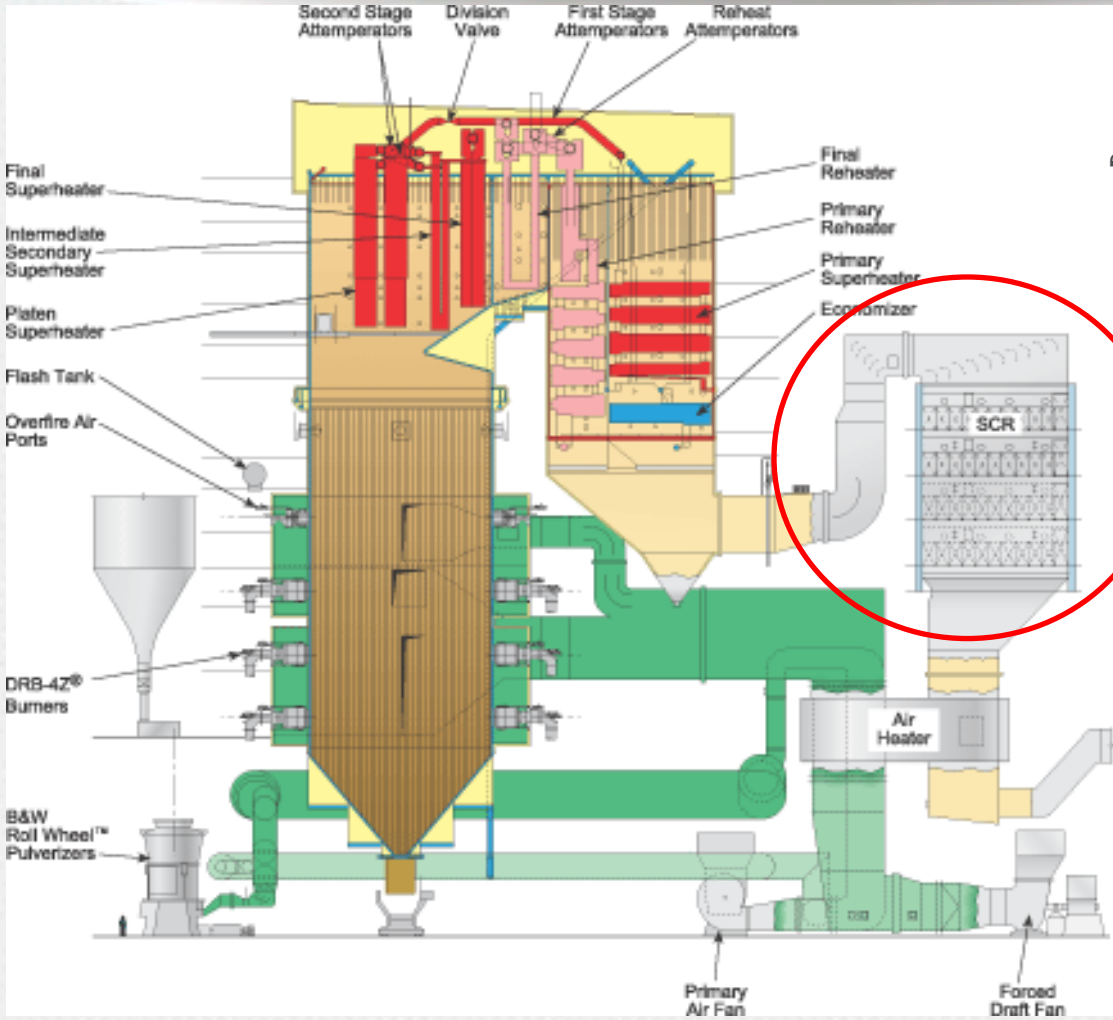

“High-dust” SCR

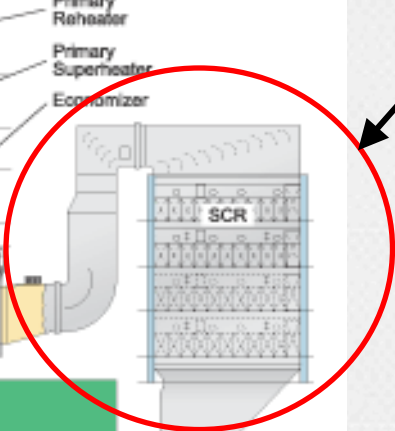



# Catalyst Deactivation by Application/Fuel

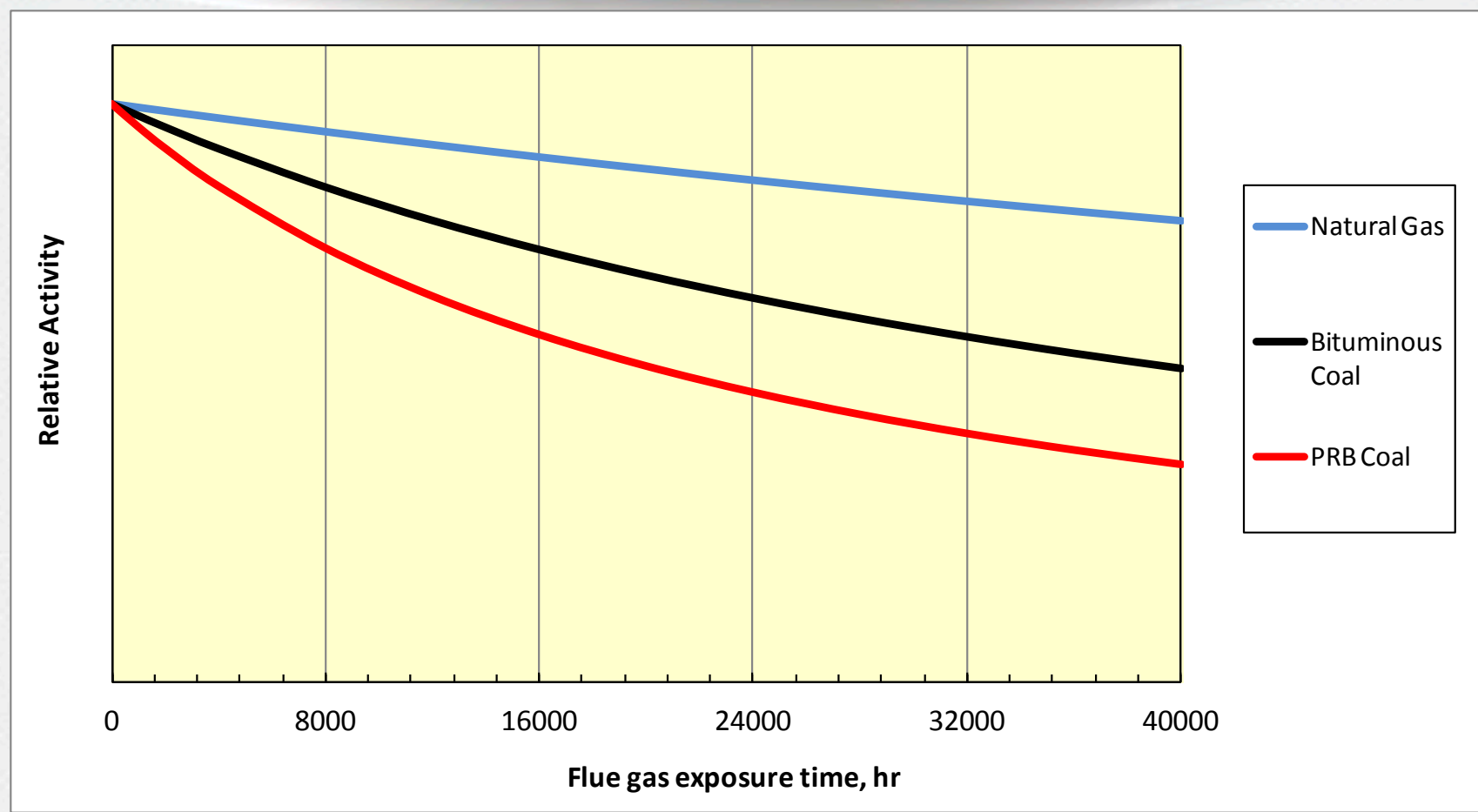

# Catalyst Deactivation Mechanisms

- Poisoning – chemical deactivation of active sites by
- Fouling – Surface deposits and pore structure plugging
- Thermal degradation/sintering – loss of pore structure and active site dispersion

# SCR Catalyst Testing Scales

- Bench-scale:  
test reactor sized for full-length sample elements  
150 mm x 150 mm (6" x 6") cross-section  
combustion based flue gas
- Micro-scale:  
test reactor holds smaller coupons cut from full size elements  
1" x 1" cross-section by 100 to 400 mm length  
Synthetic flue gas – fed by gas cylinders
- Semi-bench(?):  
test reactor cross-section between bench and micro-scales  
less than full length elements  
combustion based flue gas

# Bench-Scale Test System

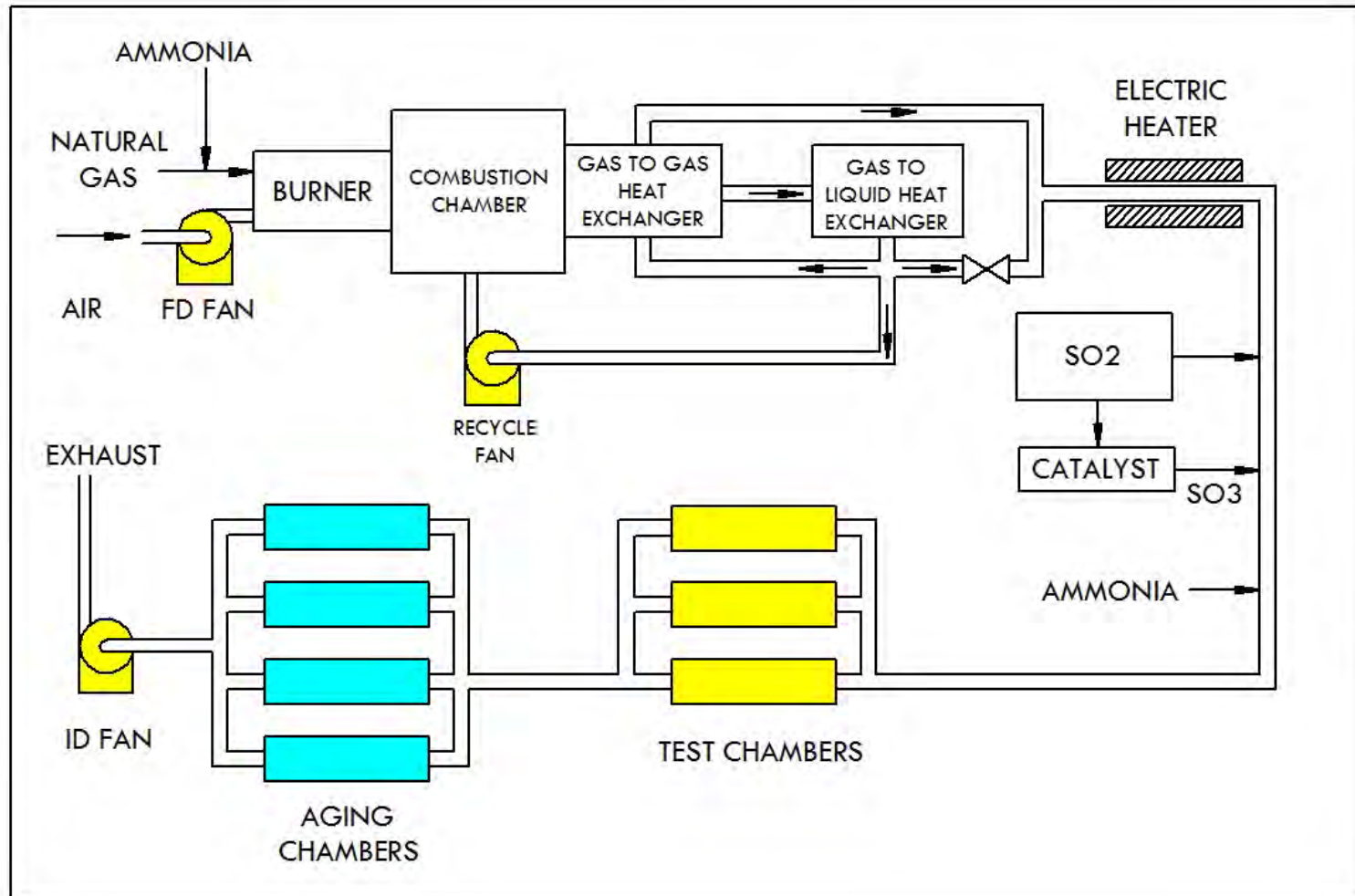

# Features of Bench-Scale Testing Systems

- Combustion based flue gas, with most flexible controls to mimic conditions of full-scale systems – temperature, flow, composition
- Accommodate full-size catalyst elements
- Preserve flow dynamics through the catalyst channels
- Preserve deactivation profile of a full-layer → reaction kinetics/diffusion properties

# Sample Coupons – Full Elements vs Micro-Scale

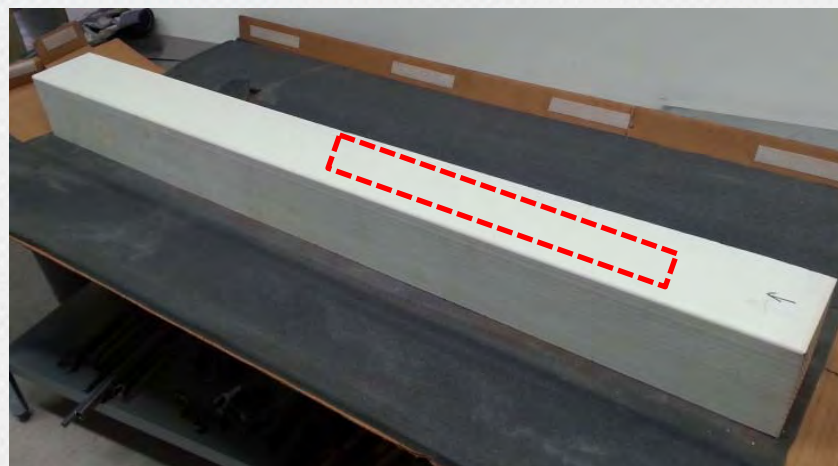
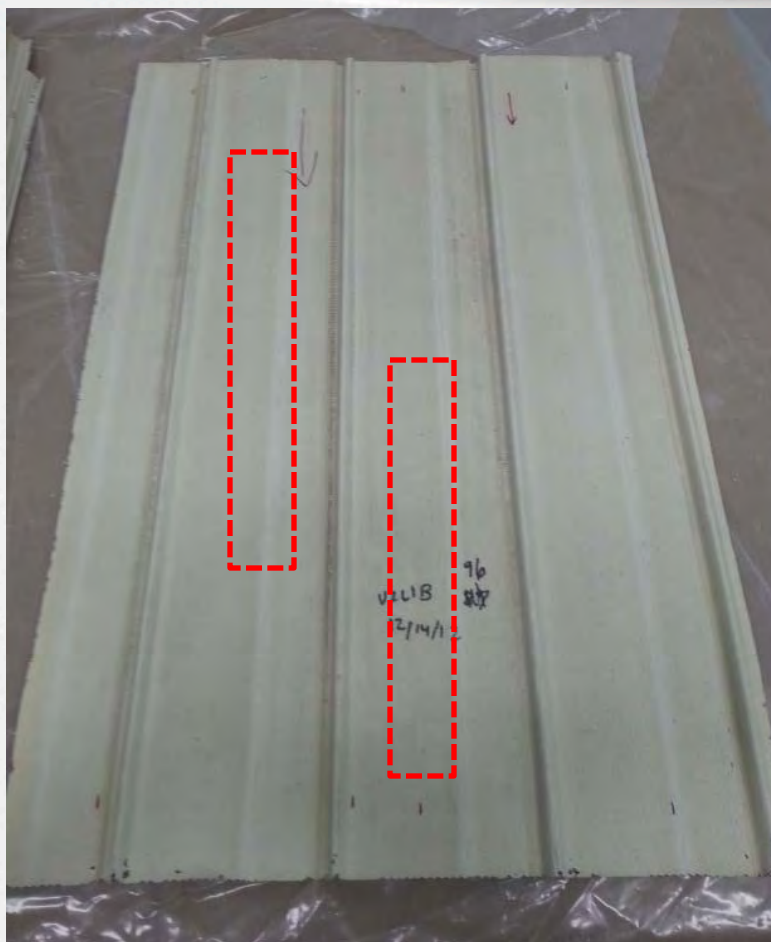

# SCR Catalyst Structures



Plate



Honeycomb



Corrugated

# Catalyst Sampling – Honeycomb

- Sample size – 1 full block
- Cross-section: 150 mm x 150 mm
- Length: full block length, up to 1350 mm
- Field sampling – 1 block per layer per reactor
- Modules with removable/replaceable element(s)

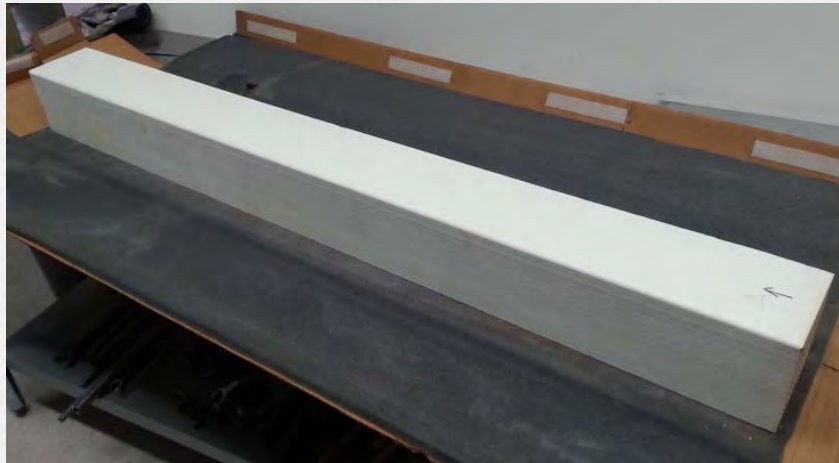

# Honeycomb Test Elements



# Honeycomb Test Element



# Honeycomb Test Element



# Geometric Measurements - Honeycomb

- Cell Count
- Blocked Cells
- Element Length
- Cross-section
- Inner wall thickness
- Cell opening width

To Determine:

- Geometric Surface Area
- Linear Velocity in Channels



# Catalyst Sampling – Plate type

- Sample size – 150 mm x 150 mm test box with 22 – 26 coupons
- Coupons cut from full plates
- Length: 1 sub-layer, up to 750 mm
- Field sampling – 16 plates per layer per reactor, plates pulled in pairs from any module



# Plate Samples



# Plate Catalyst Sample Coupons



# Plate Samples - Damage



# Geometric Measurements - Plate

- Number of plates
- Coupon Length
- Coupon Width
- Inner box cross-section
- Plate thickness

To Determine:

- Geometric Surface Area
- Linear Velocity in Channels



# Catalyst Sampling – Corrugated



# Geometric Measurements - Corrugated

- Outer Element Dimensions:  
Face cross-section  
Length
- Rely on manufacturer for:  
Specific Surface Area  
Open Area, channel size

To Determine:

- Geometric Surface Area
- Linear Velocity in Channels



# Bench-scale Measurements

- deNO<sub>x</sub> activity,  $k_{\text{NOx}}$   
indicator of catalyst's ability to reduce NOx  
measure deNOx across catalyst, calculate  $k_{\text{NOx}}$   
initial, new/fresh activity –  $k_0$   
measurements after aging / flue gas exposure –  $k_t$   
relative activity =  $k_t/k_0$  indicator of deactivation, remaining lifetime
- SO<sub>2</sub> to SO<sub>3</sub> Conversion  
measure of undesired side reaction  
can vary over time with deposits from flue gas/fly ash
- Differential pressure

# Test Conditions

- Test element loaded in chamber and sealed with insulation
- Flue gas conditions set to closely match plant conditions:
  - Temperature
  - Volumetric flue gas flow rate set to match channel velocity
  - O<sub>2</sub> and H<sub>2</sub>O concentration at catalyst inlet
  - NO<sub>x</sub> and SO<sub>2</sub> at catalyst inlet
  - SO<sub>3</sub> typically not added at catalyst inlet, typical value ~0.5 ppm
- NH<sub>3</sub>/NO<sub>x</sub> ( $\alpha$ ):
  - $\alpha = 1.0$  for deNO<sub>x</sub>
  - $\alpha = 0.0$  for SO<sub>2</sub>-SO<sub>3</sub> conversion

# Sample Conditioning

- Period of exposing catalyst to flue gas at target temperature and SO<sub>2</sub> concentration before performance measurements
- Necessary for catalyst to reach equilibrium
- Complete when deNO<sub>x</sub> Activity and SO<sub>2</sub>-SO<sub>3</sub> stop trending
- Time duration requirements (some disagreement)  
New or Freshly regenerated catalyst: 72 hours  
Catalyst previously exposed to flue gas: 12 hours

# deNO<sub>x</sub> Activity, *k*

- NH<sub>3</sub>/NO<sub>x</sub>, = 1.0
- NO<sub>x</sub> conversion,  $\eta_{NOx}$

$$\eta_{NOx} = \frac{[NOx]_{in} - [NOx]_{out}}{[NOx]_{in}}$$

- deNO<sub>x</sub> activity,  $k_{NOx}$

$$k_{NOx} = -AV \ln(1 - \eta_{NOx})$$

- Area Velocity, *AV*

$$AV = \frac{\dot{V}_{fg}}{A_{gs}}$$

- NO<sub>x</sub> concentrations (NO & NO<sub>2</sub>) by FTIR, Chemiluminescence
- NH<sub>3</sub> concentration by FTIR  
IC, TKN (reference CTM-027)

# Agreement in Measurements

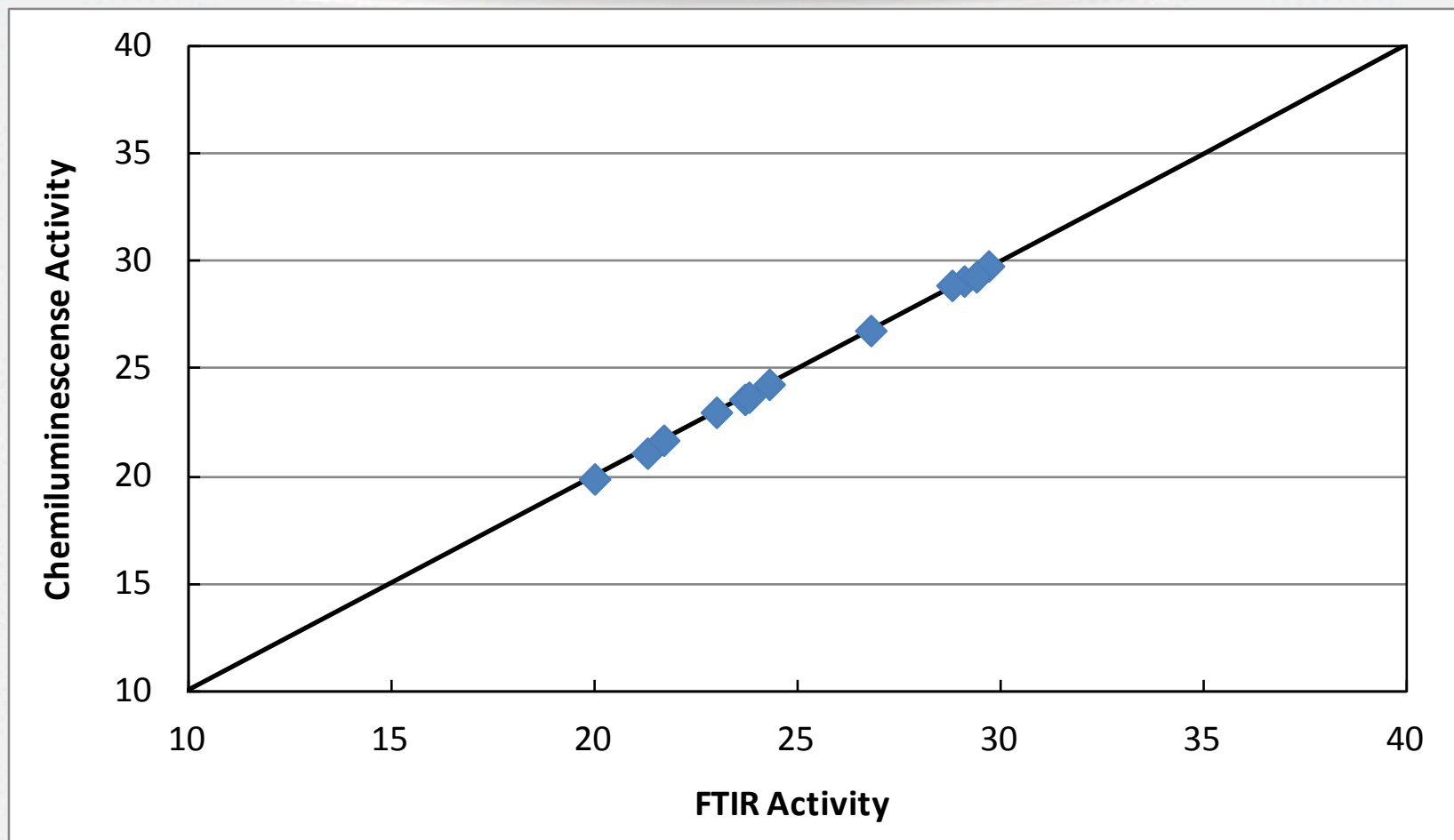

# deNOx Data

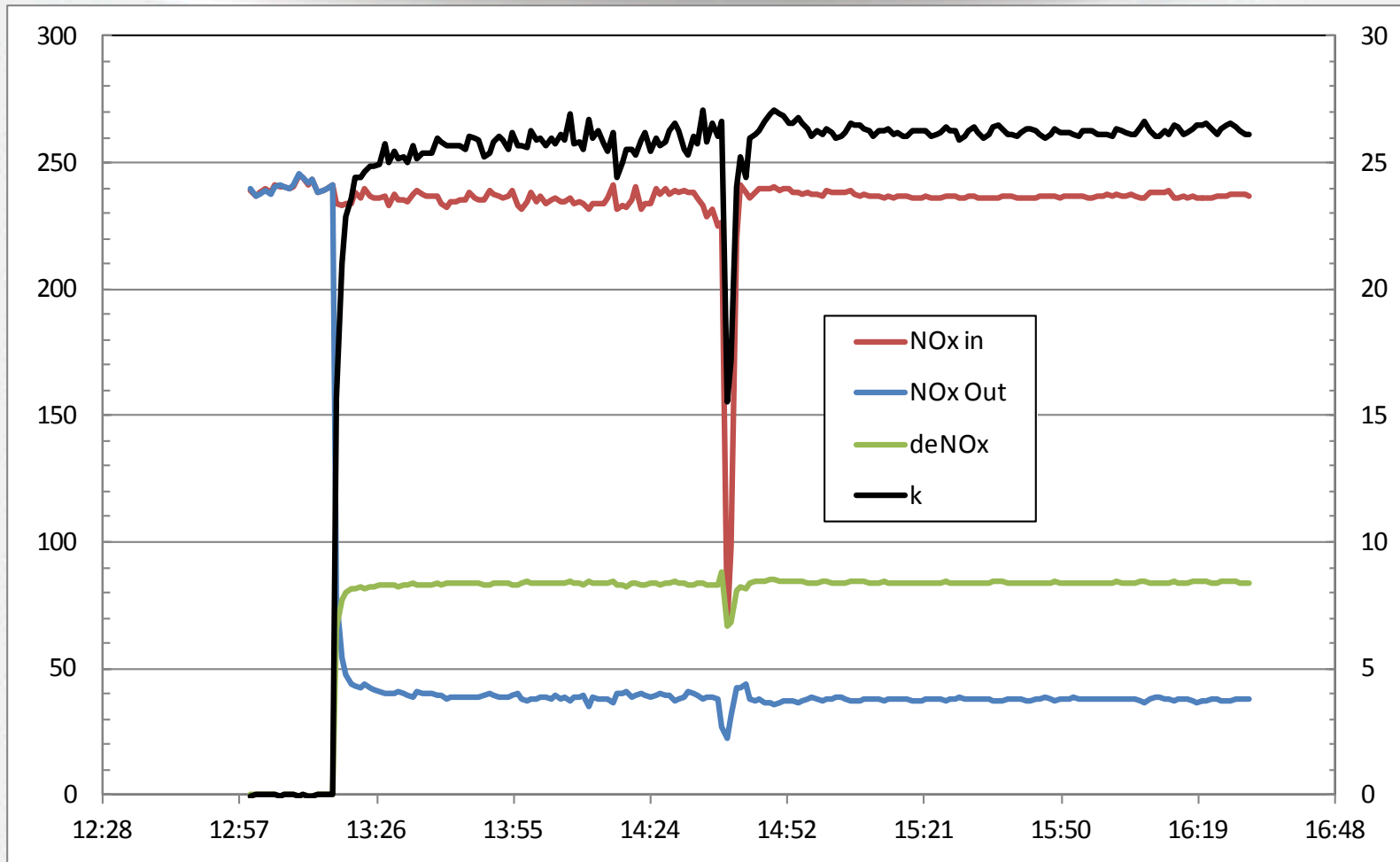

# deNO<sub>x</sub> vs NH<sub>3</sub>/NO<sub>x</sub>

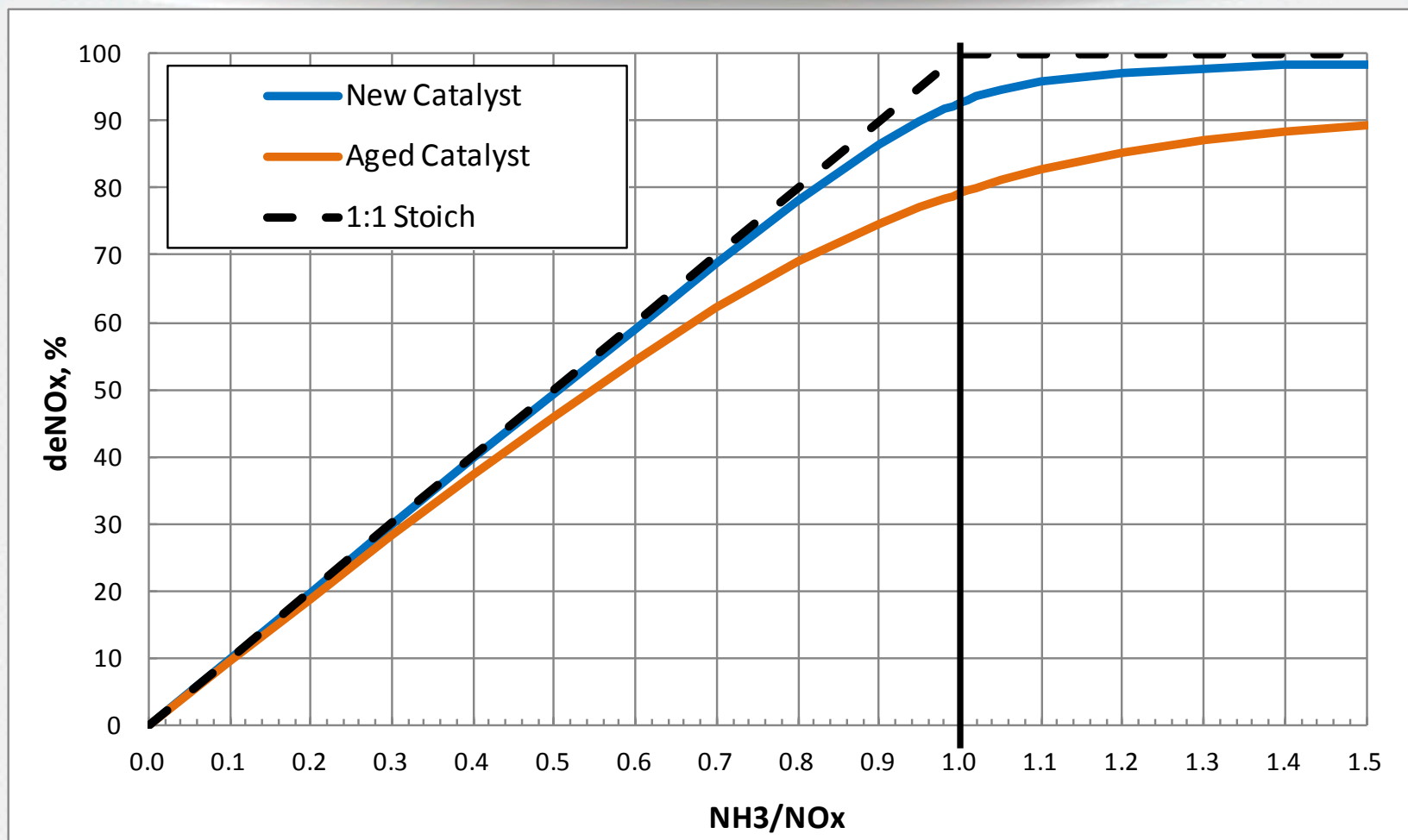

# deNOx Performance vs Area Velocity

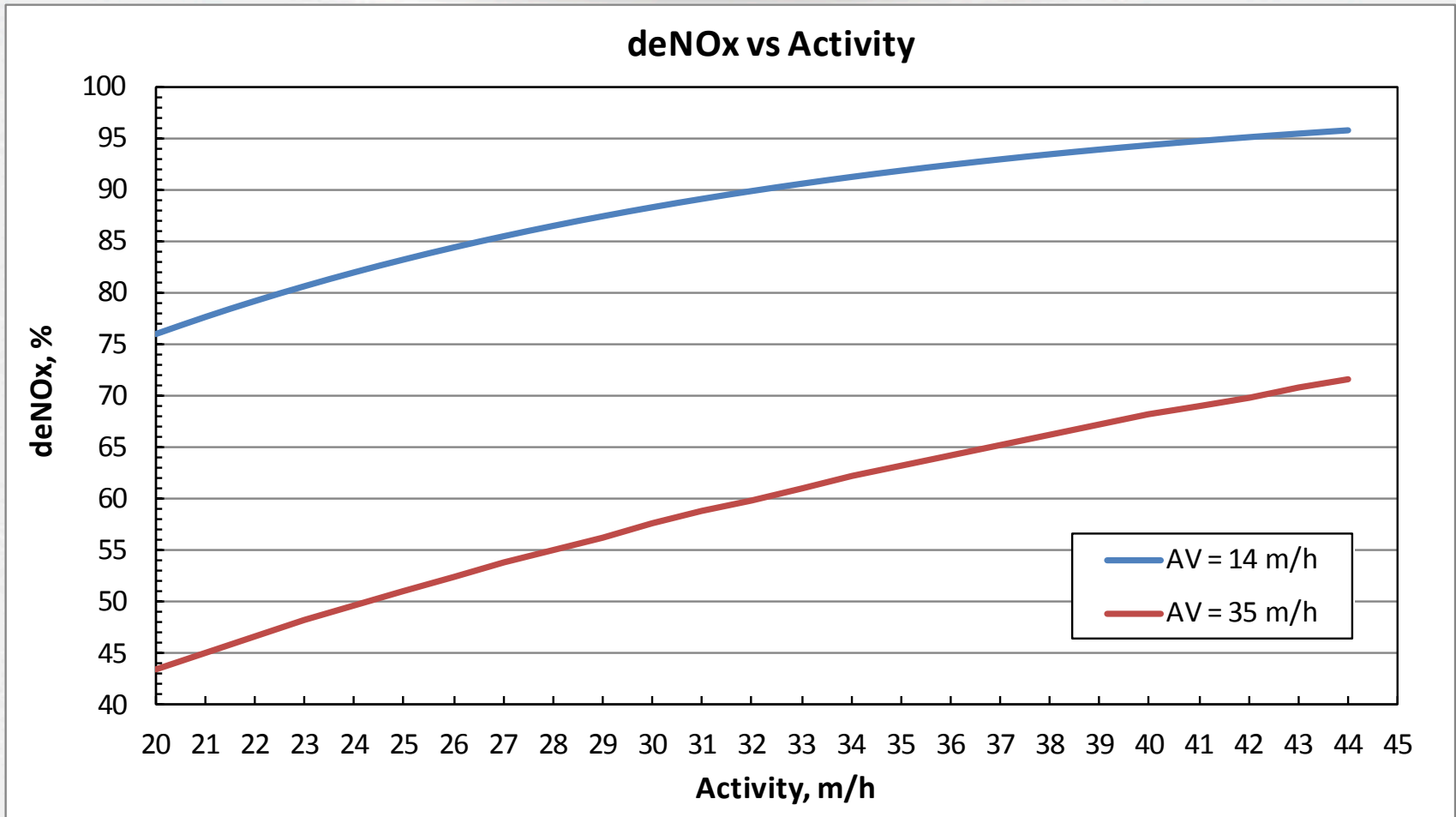

# Activity vs deNOx

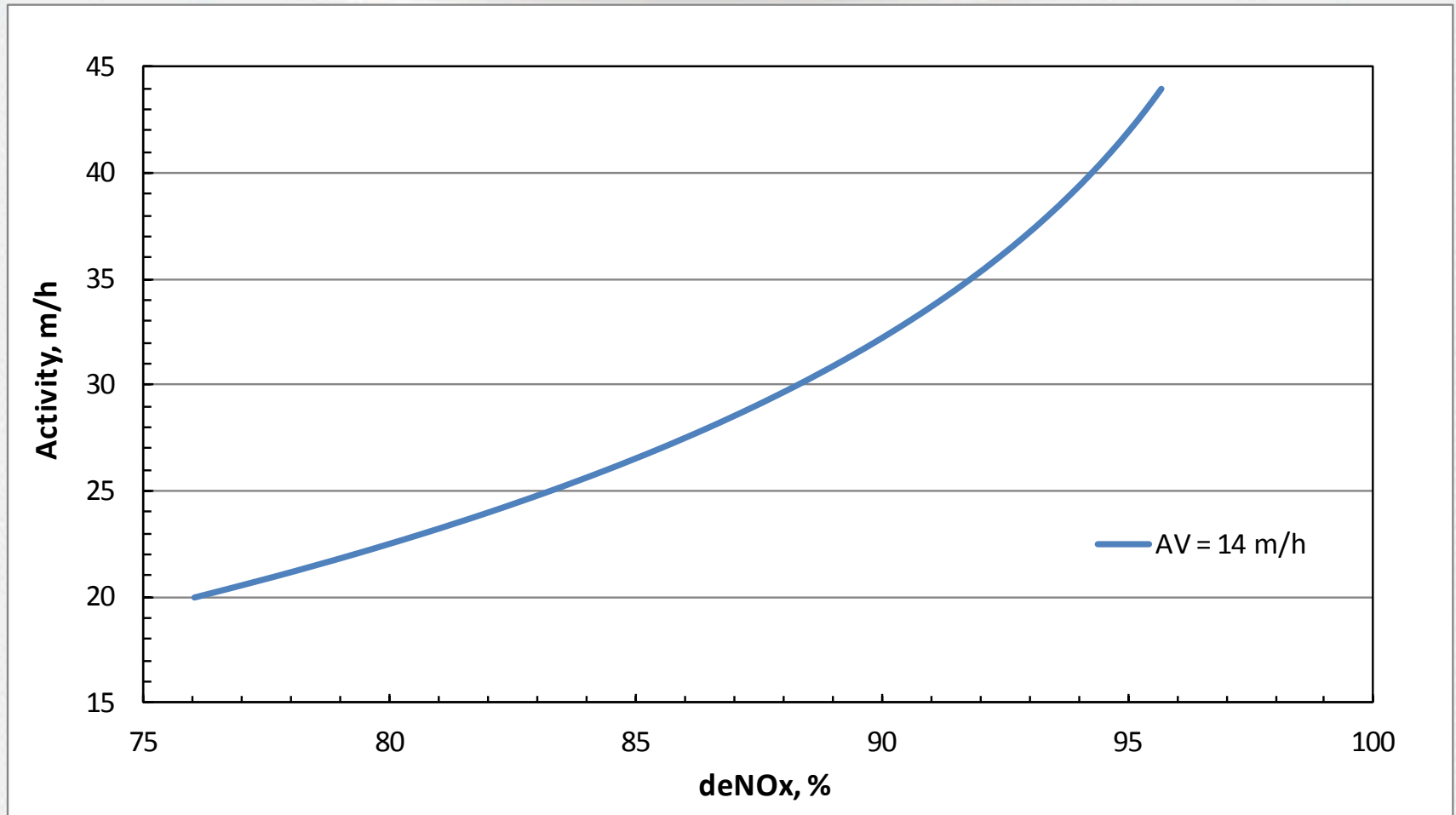

# Sensitivity – k variation vs NOx out variation

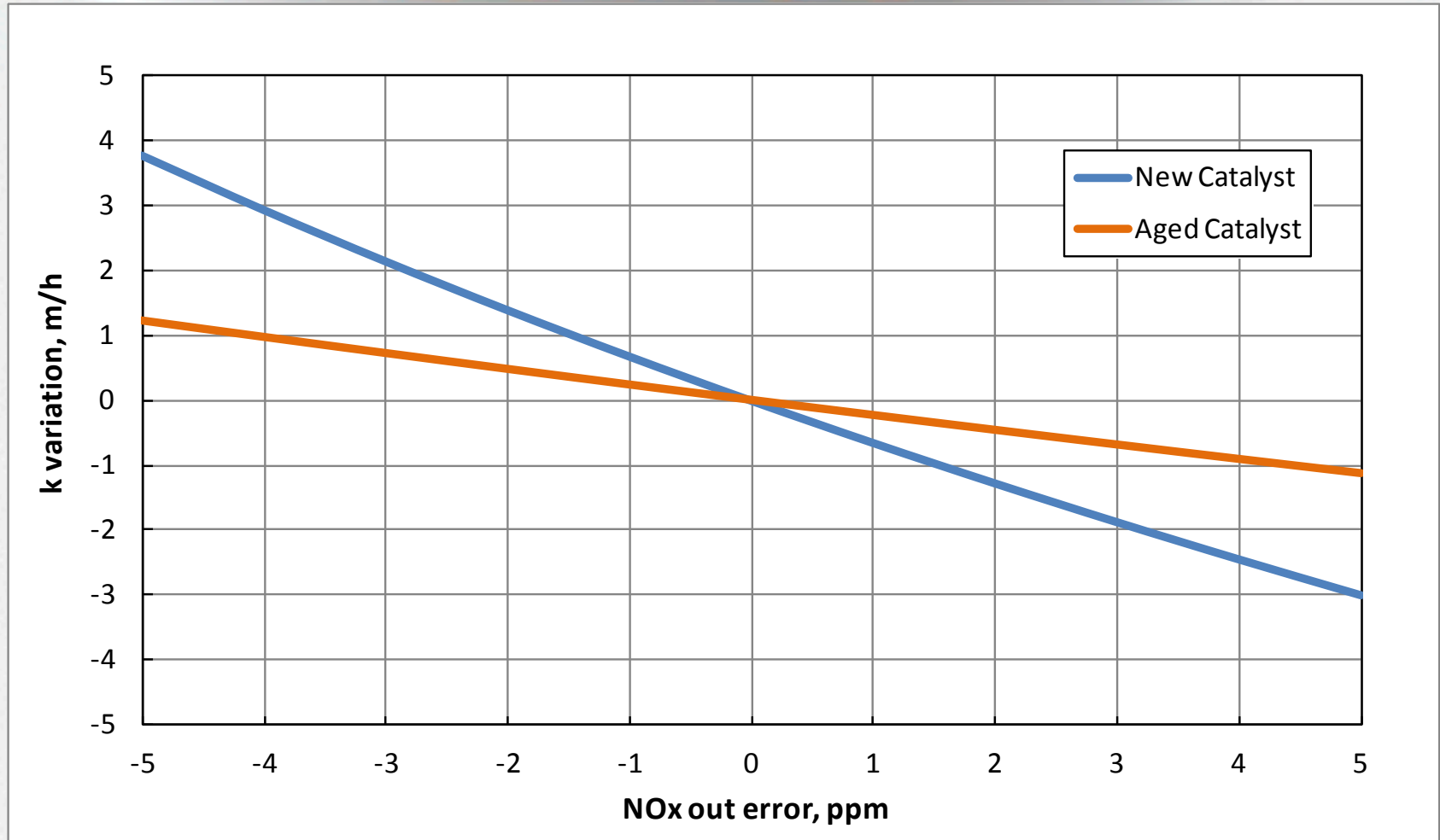

# SO<sub>2</sub> to SO<sub>3</sub> Conversion

- Calculation:

$$SO_2 \text{ Conversion} = 100 \times \left( \frac{[SO_3]_{out} - [SO_3]_{in}}{[SO_2]_{in}} \right)$$

- SO<sub>2</sub> concentration by FTIR, UV
- SO<sub>3</sub> concentrations by controlled condensation (ref Method 8A)

# Controlled Condensation for SO<sub>3</sub> Sampling

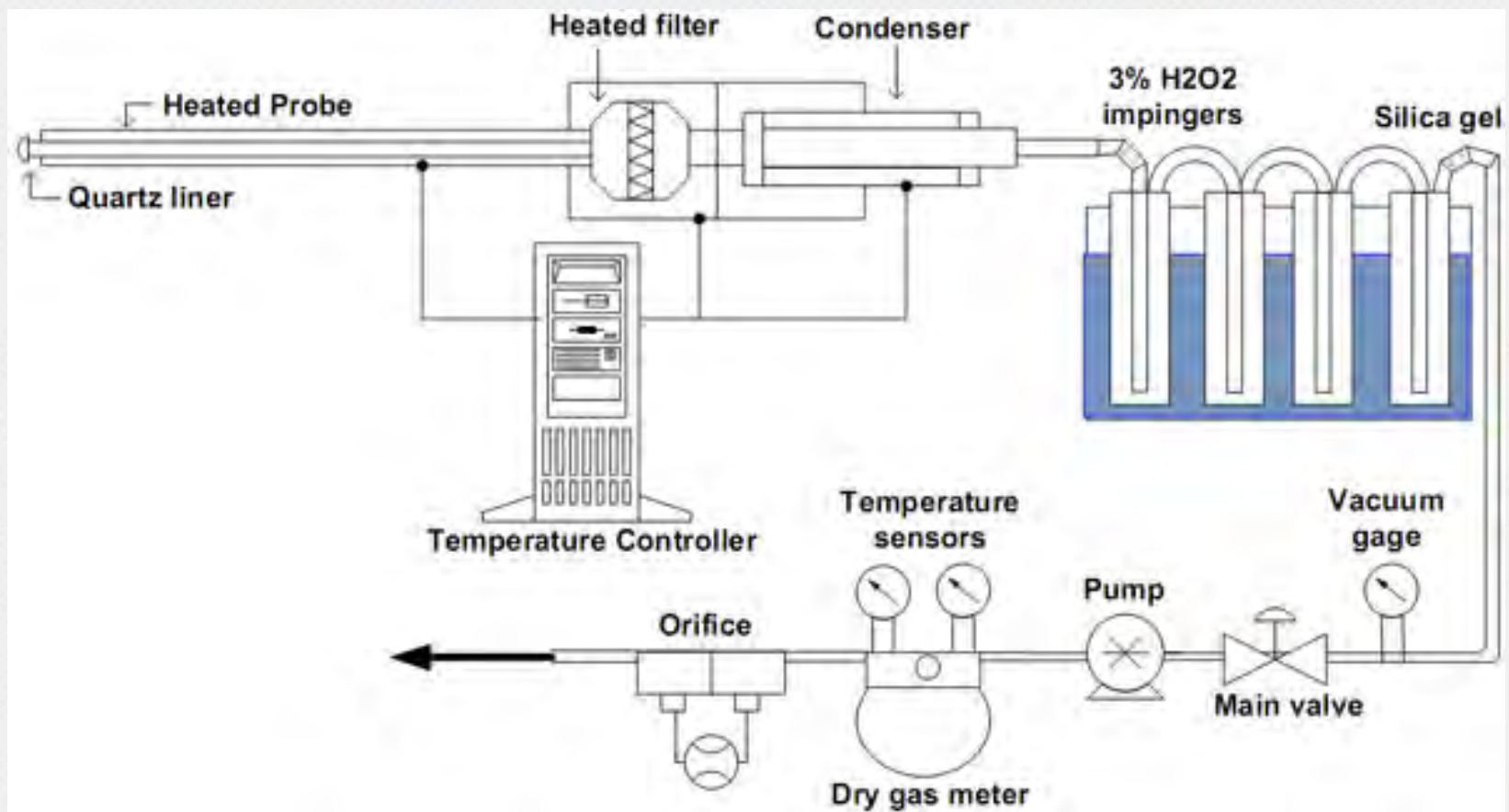

# SO<sub>2</sub>-SO<sub>3</sub> Measurement Challenges

- Low conversion measurements with low inlet SO<sub>2</sub> is difficult
- Some sensitivity to variation/error in SO<sub>2</sub> concentration
- Huge sensitivity to variation in SO<sub>3</sub> measurement

# SO<sub>2</sub>-SO<sub>3</sub> vs SO<sub>2</sub> Variation

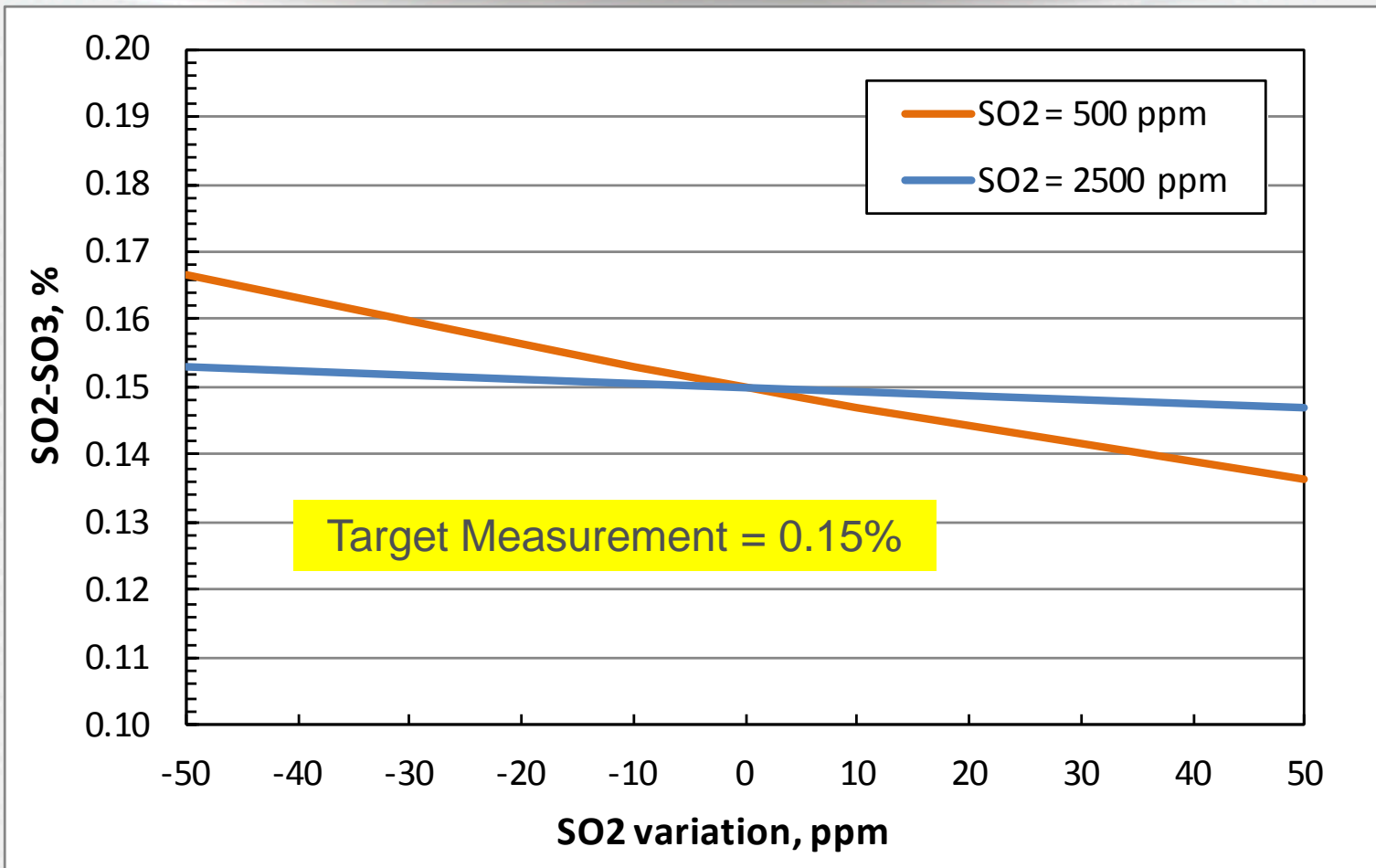

# SO<sub>2</sub>-SO<sub>3</sub> vs SO<sub>3</sub> Variation

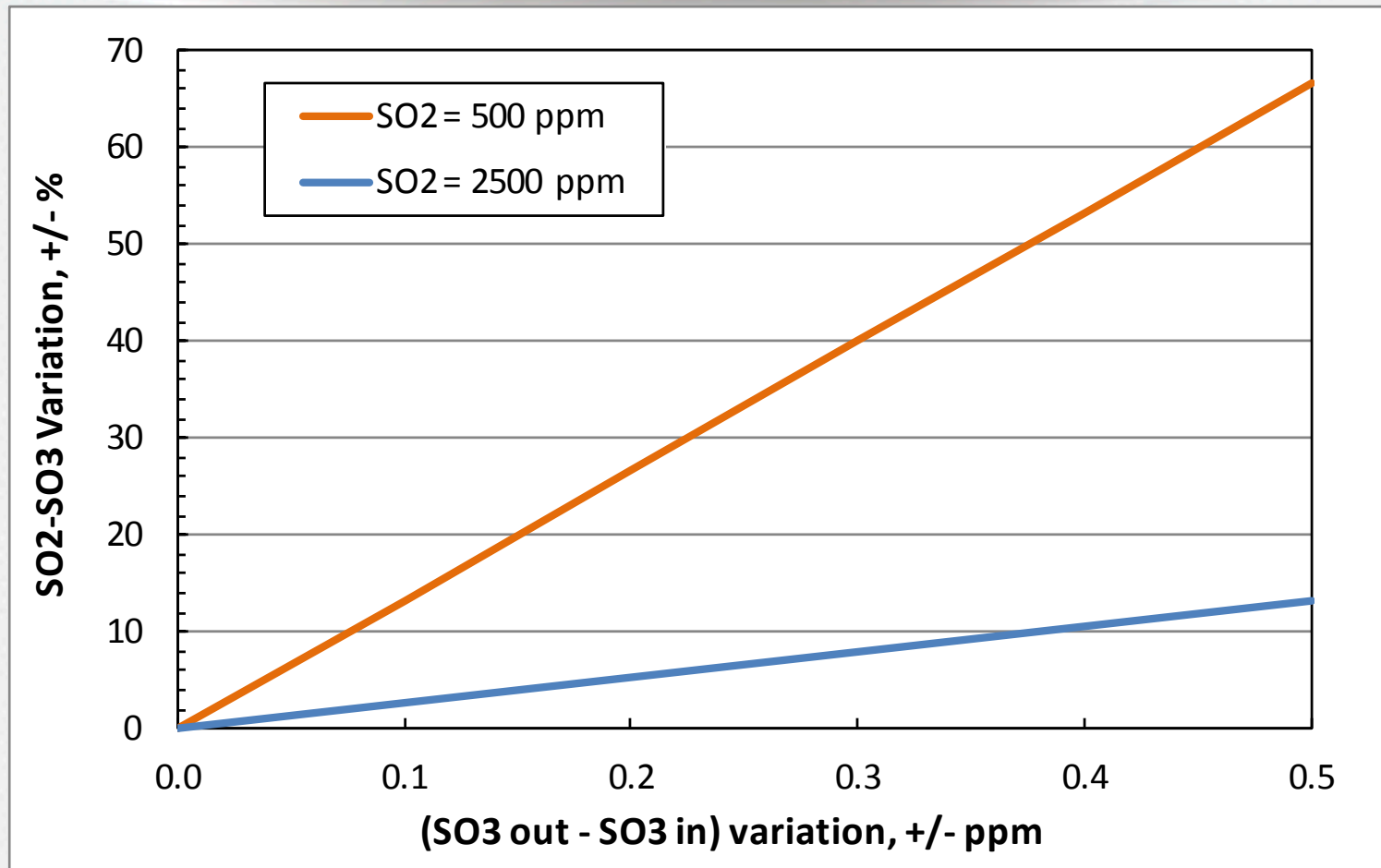

# SO<sub>3</sub> Produced by Catalyst

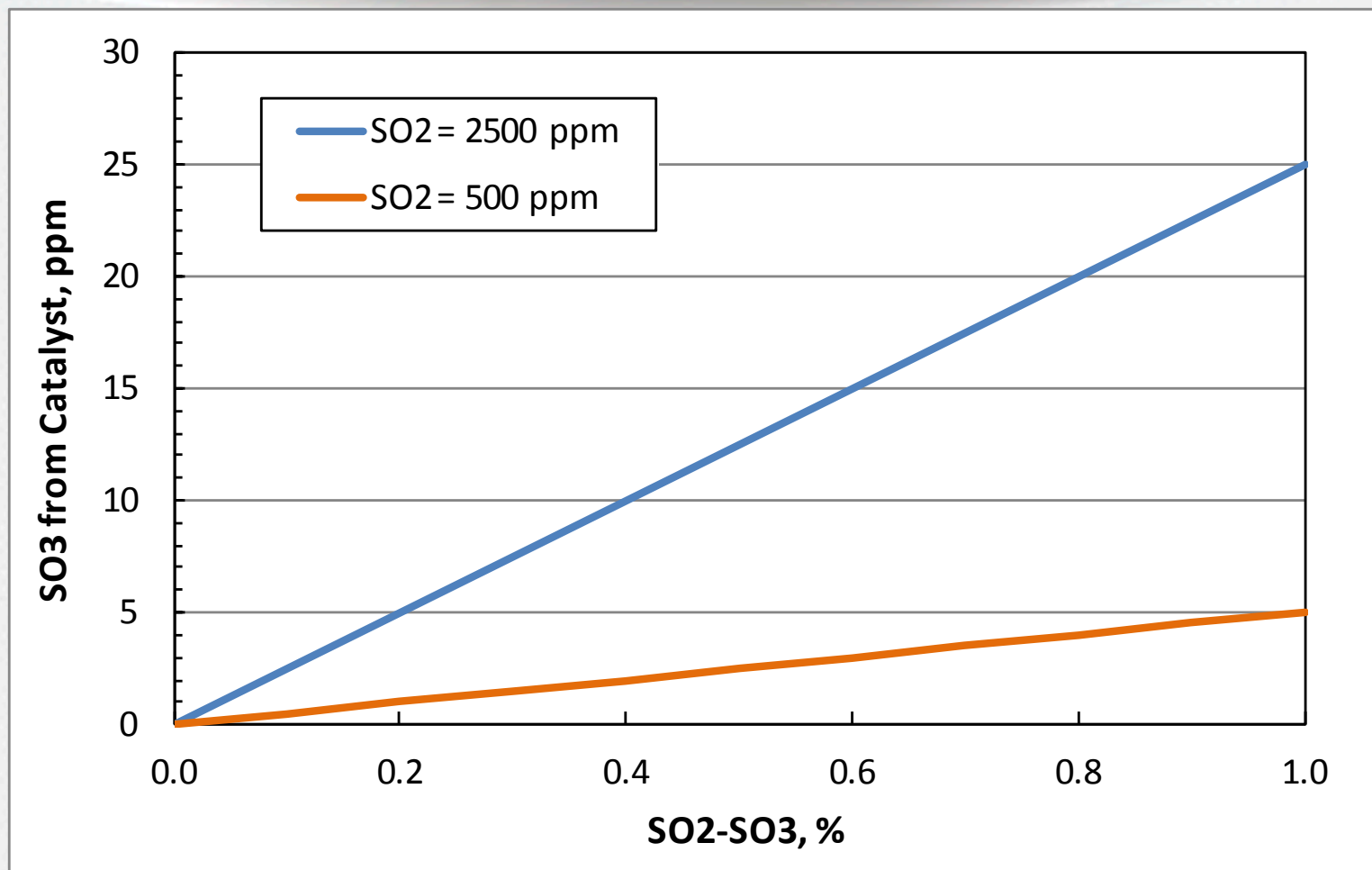

# SO<sub>2</sub>-SO<sub>3</sub>, Sample-to-Sample Variation

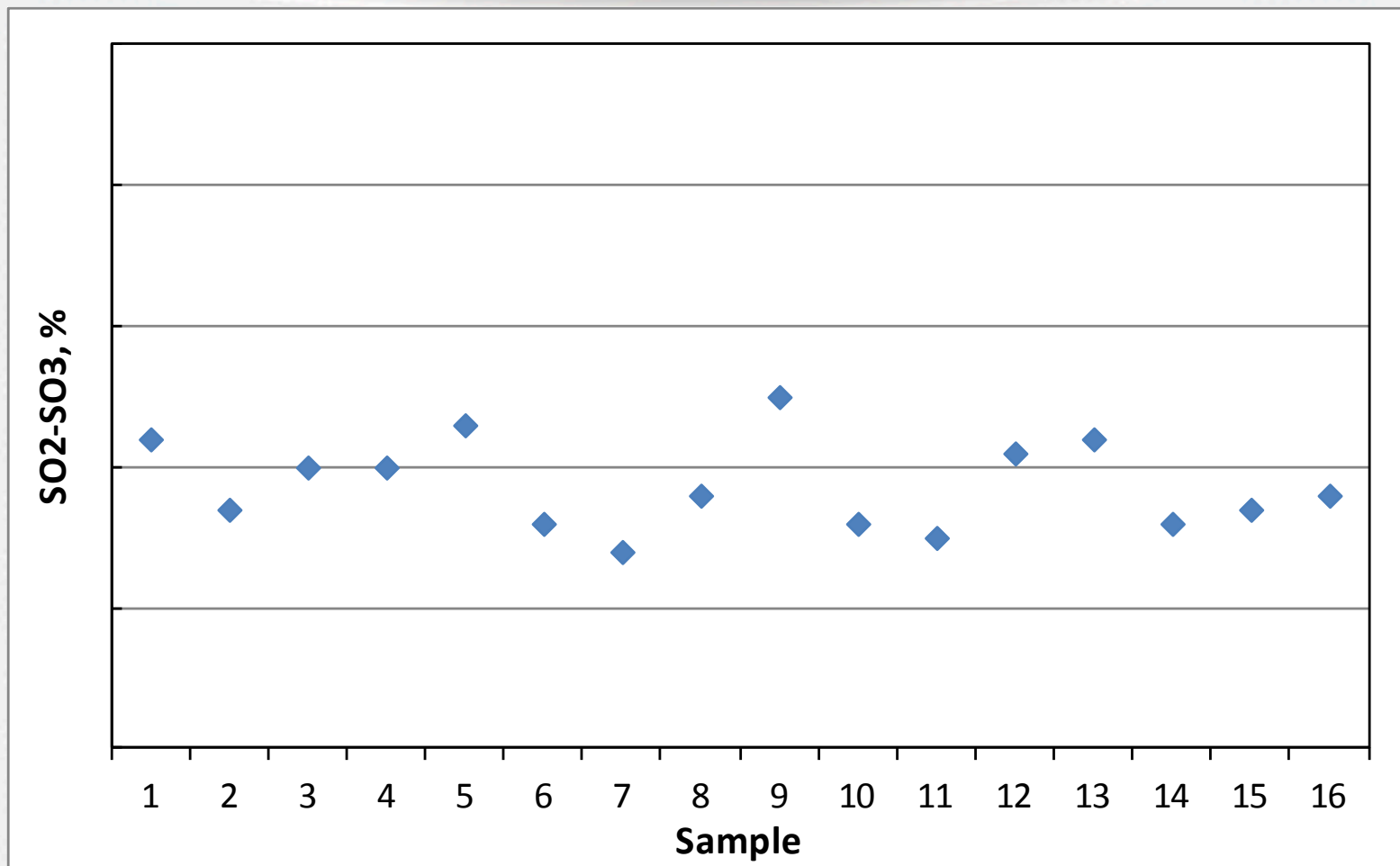

# Catalyst Management

- Maintaining SCR catalytic potential to achieve desired NO<sub>x</sub> reduction, ammonia slip limit . . . and Hg oxidation performance
- Determining deactivation trends and forecasting catalyst life based on sample activity measurements
- “What if . . .” projections for variation in operating conditions, changes in target NO<sub>x</sub> reduction performance, etc

# Basic Catalyst Management Plan

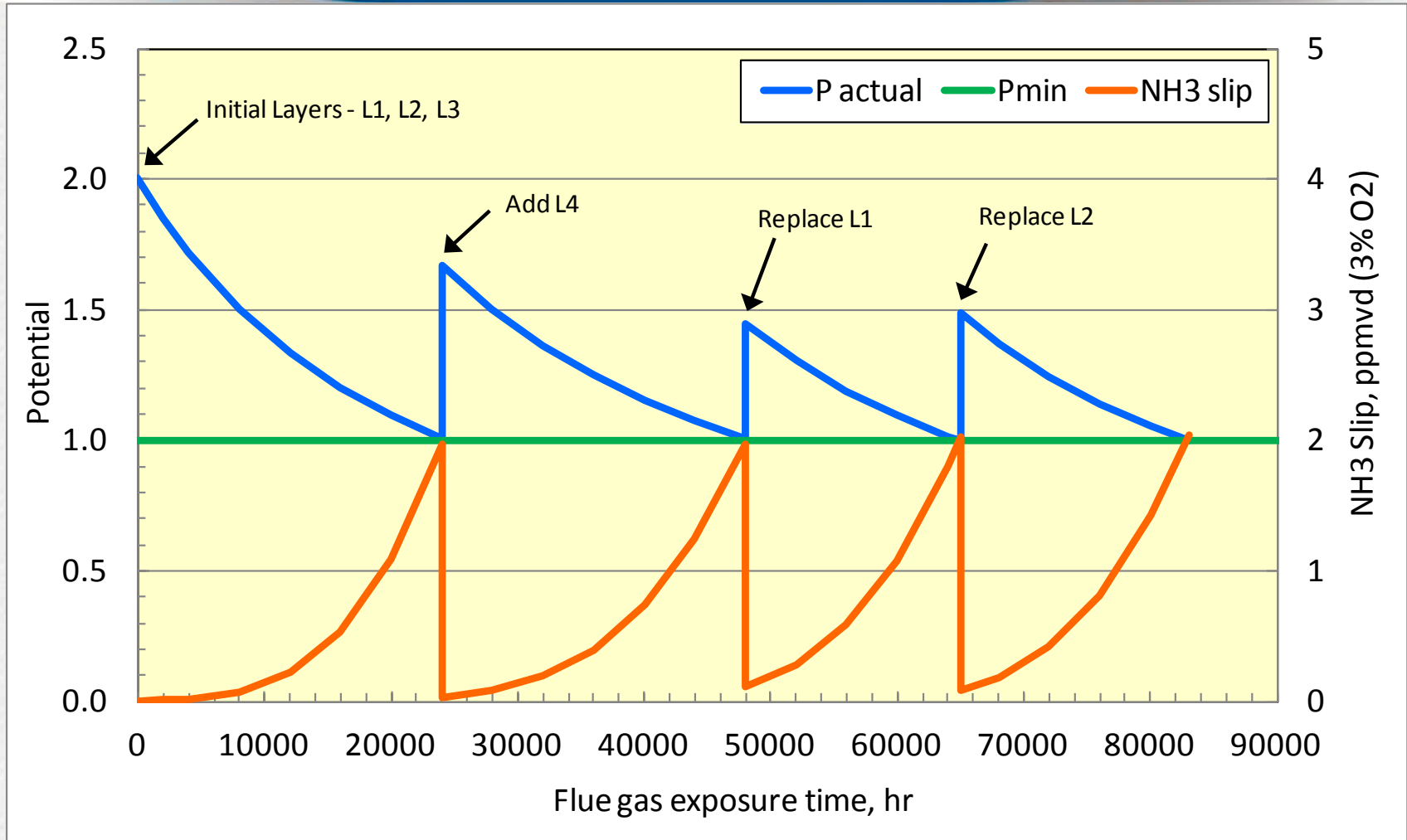
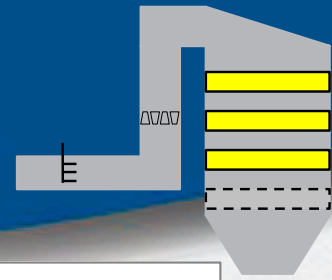

# Minimum Potential

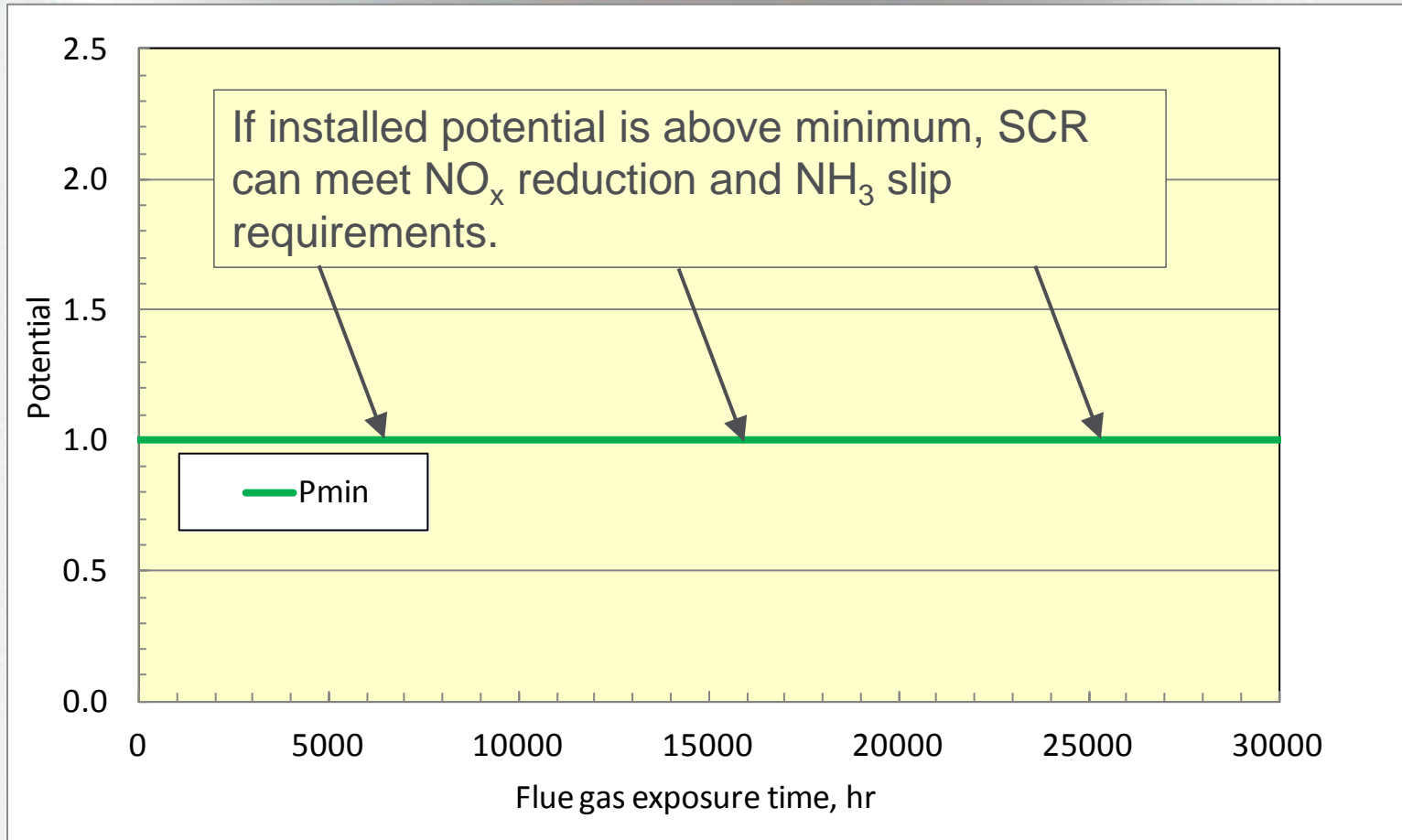

# Catalyst Deactivation & Lifetime

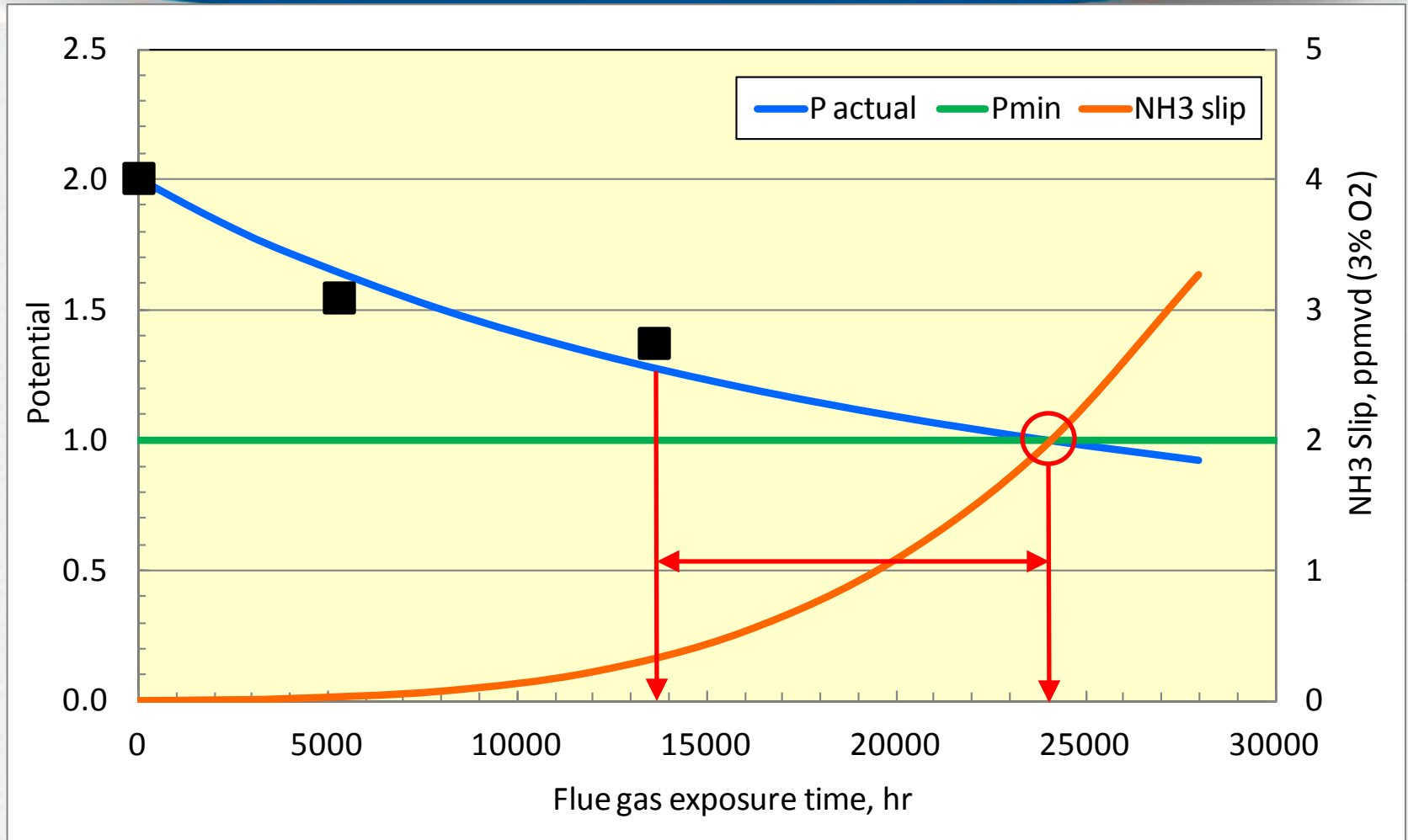

# deNOx Activity History Data

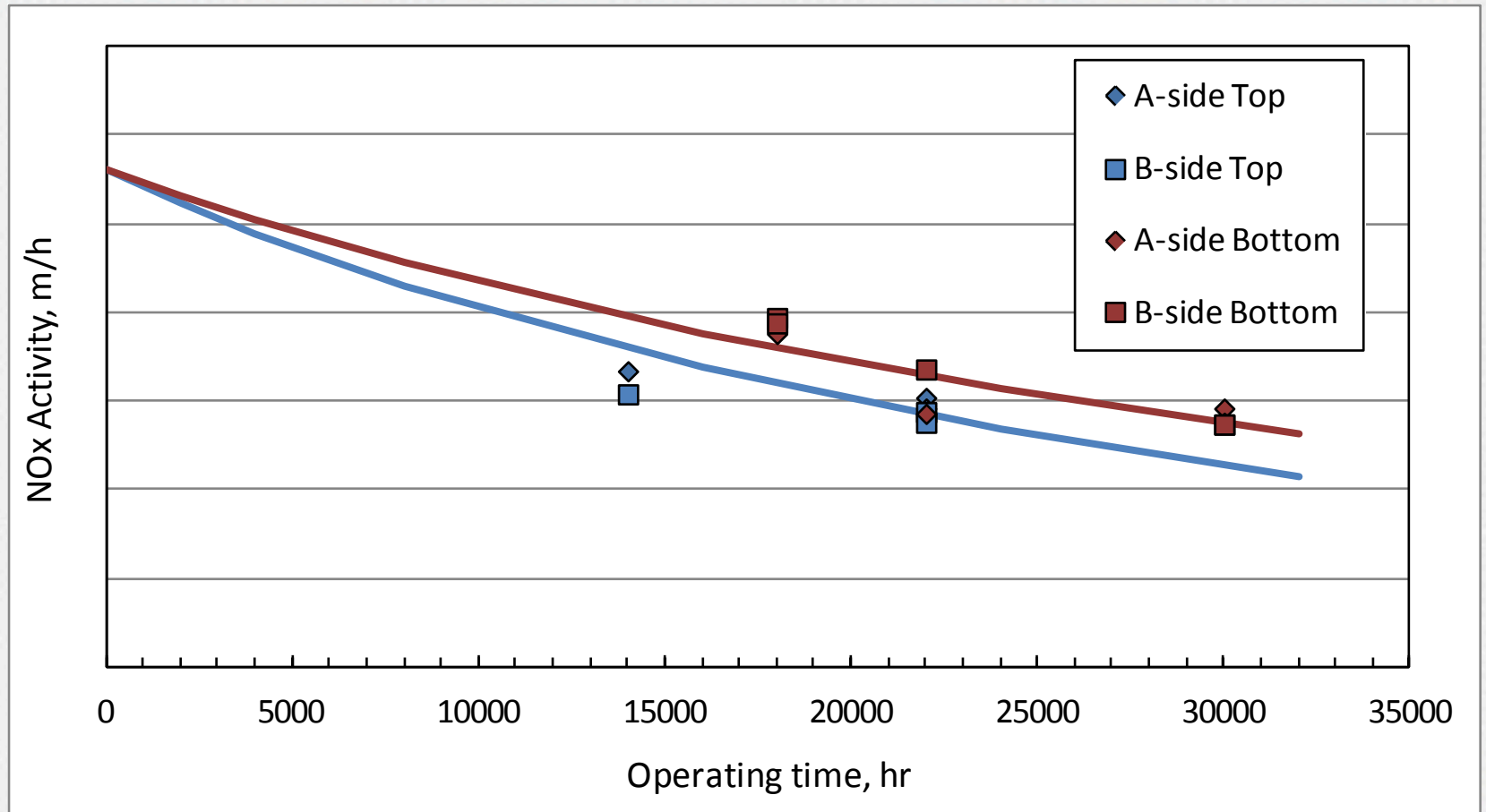

# Summary

- SCR catalyst deactivates
- Bench-scale testing is a proven method for quantifying catalyst performance – especially individual layers
- Bench-scale testing data helps to optimize catalyst replacement strategy and scheduling

*Thank You!*

